



16 John Street Port Macquarie, NSW

 3

 1

 1

Renovated Bungalow Minutes' Walk from Beaches

A sanctuary for carefree living, this relaxed and very comfortable home is a unique, once in a generation opportunity! Occupying a prized location just five minutes stroll from unspoilt beaches, this enchanting address offers a premier coastal lifestyle.

Immerse yourself in the Flynns and Shelly Beach celebrated surf and cafe scene and enjoy an endless summer. Cafes, restaurants, local convenience shopping and post office are just minutes from your door.

Exuding classic beach cottage charm, this beautifully styled coastal home offers an oasis of light filled living.

Beautifully preserved features entwine with contemporary updates in keeping with the origi...

Price: Auction Postponed

Council Rates: \$2,650.00/year (approx)



Michelle Percival

0404 466 500

Ally Downing

0417 929 726



FLOOR PLAN
(92 sq m Approx)

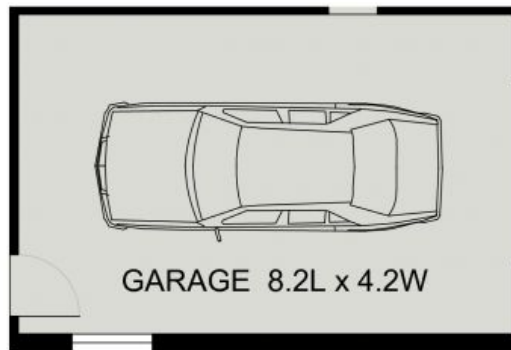

GARAGE UNDER

16 JOHN STREET
PORT MACQUARIE