



3/11 Norfolk Avenue Port Macquarie, NSW



Refreshed East Port Unit - Walk to Town & Beaches

Refreshed for comfortable living with new paintwork, timber look vinyl plank flooring and ceiling fans to living and bedrooms, its aspect and elevation offers a tranquil leafy outlook from the generous lounge/dining and covered outdoor terrace.

Capturing coastal cross breezes and a private and calming treed outlook, this cul de sac location places you a three minute stroll from the coastline and its renowned walks with beaches, vibrant cafe culture and Port Macquarie's CBD walking distance from your door.

In a complex of only six, this well priced unit is ideal for those starting out, down sizing or the investor wishing to add to their portfolio. Perfectly priced for those wanting t...

Price: \$329,950

Council Rates: \$2,000.00/year (approx)

Strata Rates: \$729.20 p/q



Michelle Percival

0404 466 500

Ally Downing

0417 929 726



FLOOR PLAN
(89 sq m Approx)

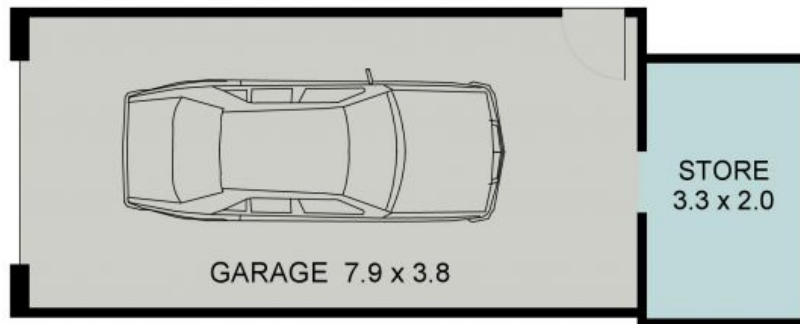

GARAGE PLAN

3/11 NORFOLK AVENUE
PORT MACQUARIE