

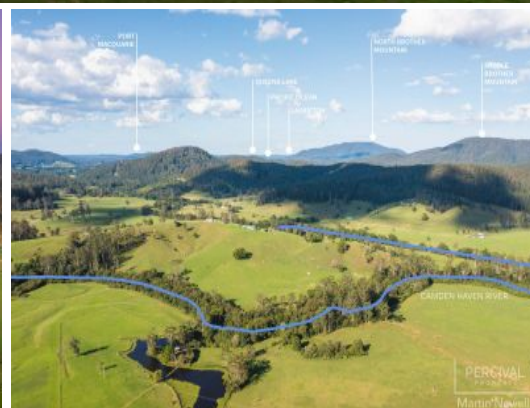

PERCIVAL
PROPERTY
Martin Newell
Rural & Residential Property



845 Lorne Road Lorne, NSW



6



3



6

Don't Miss This - Highly Productive Blue Ribbon Rural - Lorne Valley Farm - 93 A

Properties in this area are keenly sought after, however rarely available. Nevertheless, every once in a while, a very special property comes to the market, and Lorne Valley Farm, is such a property.

Entering the property via it's driveway, you rise to the peak of a ridge line where you will discover the homestead, cottage, shedding and other facilities.

Cattle handling is simplified with quality fencing, cattle yards and subdivision into 15 paddocks.

Those with horses will enjoy the stables, horse training arena, horse paddocks and the end...

Price: Guide \$1,950,000-\$2,000,000

Council Rates: \$2,600.00/year (approx)



Martin Newell

0429 883 488

Martin Newell

0429 883 488

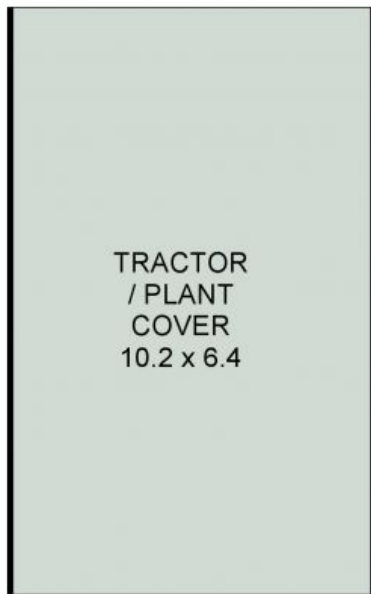

TRACTOR PORT

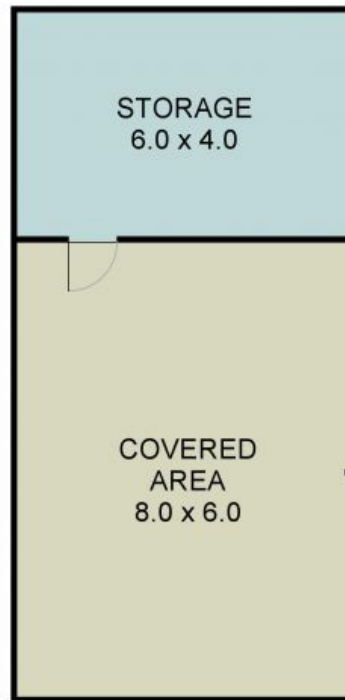

SHED 2 PLAN

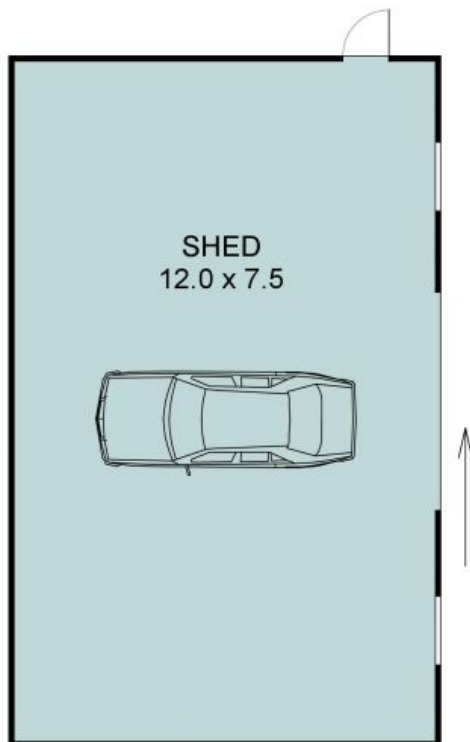

SHED 1 PLAN

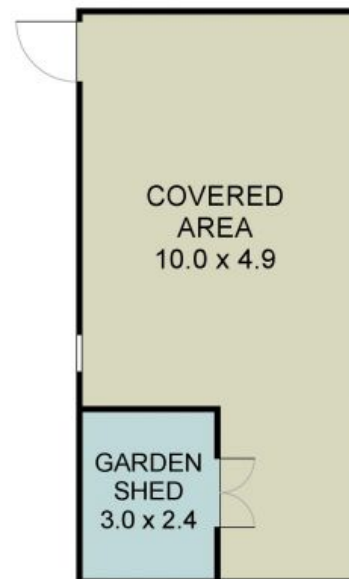

SHED 3 PLAN

845 LORNE ROAD
LORNE

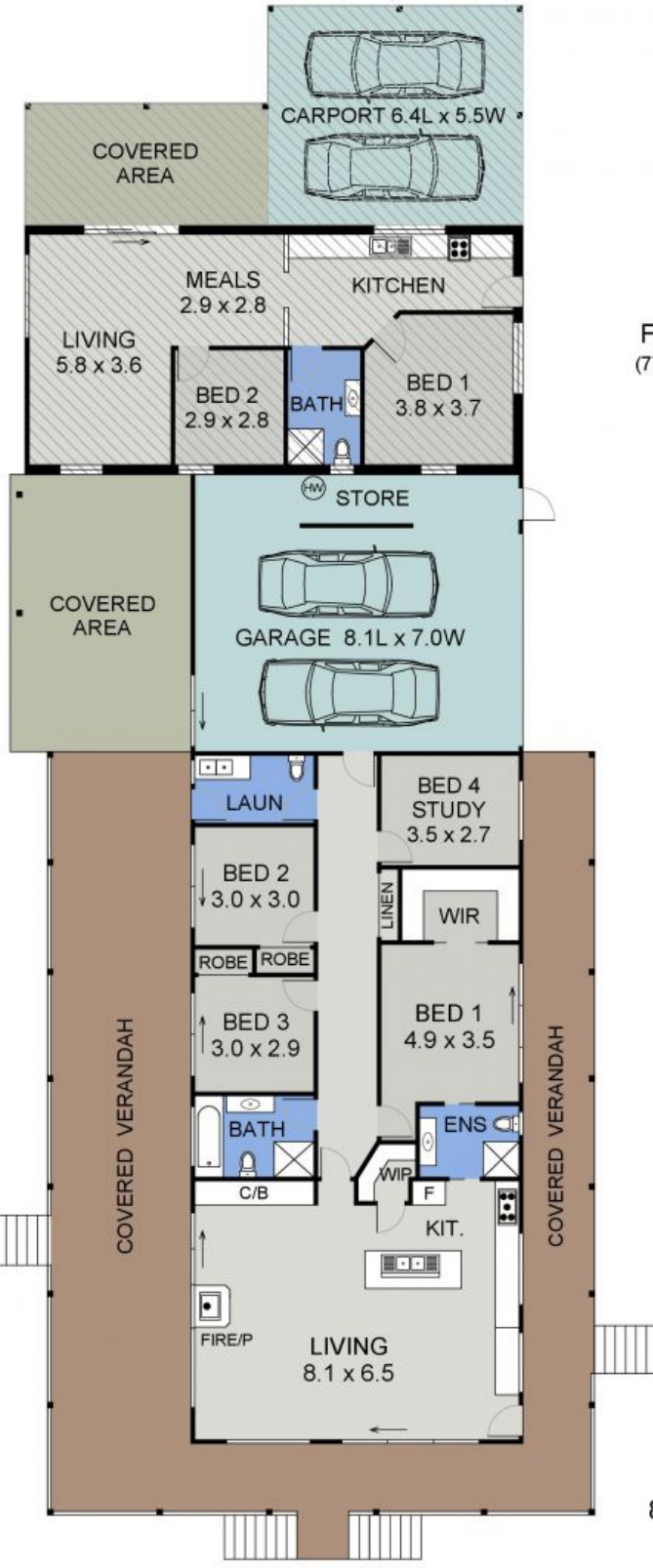

FLAT PLAN
(77 sq m Approx)

HOUSE PLAN
(204 sq m Approx)
Scale - 1:140

845 LORNE ROAD
LORNE